



POWER AVAILABILITY

PowerSure™ PST

USER MANUAL

350-500 VA
120V



TABLE OF CONTENTS

IMPORTANT SAFETY INSTRUCTIONS	1
INTRODUCTION AND SYSTEM DESCRIPTION	4
Top and Side Views of UPS	5
MAJOR COMPONENTS	6
Transient Voltage Surge Suppression (TVSS) & EMI / RFI Filters	6
Transfer Switch	6
Battery Charger	6
Battery	6
Inverter	6
WHAT'S INCLUDED	7
INSTALLATION	8
CONTROLS AND INDICATORS	10
ON/OFF/Alarm Silence Button	10
Status Indicators: Utility/Battery, Fault	11
Utility/Battery Indicator (Green)	11
Site Wiring Fault Indicator (Amber)	11
Fault Indicator (Red)	11
Location and Status of Indicators	11
MODES OF OPERATION	12
Normal Mode	12
Battery Mode	12
COMMUNICATIONS	13
USB Interface Port	13
Data Line Protection Connectors	13
MAINTENANCE	14
Cleaning the UPS	14
Maintaining Batteries	14
TROUBLESHOOTING	15
Guide to Status Indicators	15
Troubleshooting Chart	16
SPECIFICATIONS	17
Battery Run Times	18
Product Warranty Registration	18

IMPORTANT SAFETY INSTRUCTIONS

SAVE THESE INSTRUCTIONS

This manual contains important safety instructions that should be followed during the installation and maintenance of the Uninterruptible Power System (UPS) and its batteries. Please read this manual thoroughly before attempting to install or operate this UPS.

Read all safety, installation, and operating instructions before operating the UPS. Adhere to all warnings on the unit and in this manual. Follow all operating and user instructions.

This equipment is designed for Commercial, Industrial or Residential use. Liebert Corporation neither recommends nor knowingly sells this product for use in life support applications or with other designated critical devices.

This equipment can be installed and operated by individuals without previous training.



WARNING

SAFETY PRECAUTIONS

- To prevent the risk of fire or electric shock, install the UPS in a temperature and humidity controlled room, free of conductive contaminants, moisture, flammable liquids, gases and corrosive substances.
- Operate the UPS only from a properly grounded (earthed) 120VAC, 60Hz AC supply.
- To reduce the risk of electric shock, do not remove the cover, as it has no user-serviceable parts inside except the internal battery pack. Some components are live, even when AC power is disconnected. For service, contact a qualified technician.



CAUTION

Although your UPS has been designed and manufactured to assure personal safety, improper use may result in electrical shock or fire. To ensure safety, please observe the following rules:

- Turn off and unplug your UPS before cleaning. Do not use liquid or aerosol cleaners. A dry cloth is recommended to remove dust from the surface of your UPS.
- Do not install or operate your UPS in or near water.
- Do not place your UPS on an unstable cart, stand or table.
- Do not place your UPS in direct sunlight or near heat emitting sources.
- Never block or insert any objects into the ventilation holes or other openings of the UPS. Keep all vents free of dust accumulation that could restrict airflow.
- Do not place UPS power cord in any area where it may be damaged by heavy objects.
- Placing magnetic storage on the top of the UPS may result in data corruption.



CAUTION

If your UPS demonstrates any of the following conditions, turn off and unplug your UPS from the outlet and contact your local dealer, Liebert representative, or Liebert Worldwide Support Group.

- The power cord is damaged.
- Liquid has been spilled on the UPS.
- The circuit breaker or fuse opens frequently.
- The UPS does not operate in accordance with the user manual.

Provided is a USB cable for connection to a computer. Store in a safe place if not required at this time.

CONDITIONS OF USE: The input receptacle must be within 6 feet (1.8 meters) of the UPS.

Your UPS provides conditioned power to connected equipment. Maximum load must not exceed that shown on UPS rating label. If uncertain, consult your local dealer, Liebert representative or the Liebert Worldwide Support Group.

The equipment can be installed and operated by individuals without previous training.



CAUTION

BATTERY HANDLING PRECAUTIONS

Servicing of batteries should be performed or supervised by personnel knowledgeable of batteries and required precautions. Keep unauthorized personnel away from the batteries.

A battery can present a risk of electrical shock and high short-circuit current. The following precautions should be observed when working on batteries:

- Remove watches, rings, and other metal objects.
- Use tools with insulated handles.
- Do not dispose battery or batteries in a fire. The battery may explode.
- Do not open or mutilate the battery or batteries. Released electrolyte is harmful to skin and eyes. It may be toxic.
- When replacing the battery, use same number and type of battery as the suitable recommended type of battery listed in specification table in back of this manual.
- Handle, transport and recycle batteries in accordance with local regulations.

INTRODUCTION AND SYSTEM DESCRIPTION

Congratulations on your choice of the Liebert PowerSure™ PST Uninterruptible Power System (UPS). It provides filtered AC power to sensitive electronic equipment and other critical loads.

The PowerSure PST is an off-line UPS designed for desktop applications. It provides perfect one-to-one power protection for electronic equipment such as PCs, point-of-sale displays, home office equipment and similar electronic gear. The PowerSure PST is available in two (2) sizes: 350 and 500VA at 120VAC.

PowerSure PST models are available for 120VAC and 230VAC supply voltages and loads. Please verify that this model matches your AC Utility and load voltage requirements.



NOTE

This device complies with part 15 of the FCC Rules.

Operation is subject to the following two conditions: (1) This device may not cause harmful interference, and (2) this device must accept any interference received, including interference that may cause undesired operation.

This equipment uses, generates and can radiate radio frequency energy and, if not installed and used in accordance with the instructions, may cause harmful interference with radio communications. However, there is no guarantee that interference will not occur in a particular installation.

If this equipment does cause harmful interference to radio or television reception, which can be determined by turning the equipment off and on, the user is encouraged to try to correct the interference by one or more of the following measures:

- *Reorient or relocate the receiving antenna.*
- *Increase the separation between the UPS and the receiver.*
- *Connect the UPS into an outlet on a circuit different from the one on which the receiver is connected.*

Top and Side Views of UPS

Black output receptacles
Surge protection only

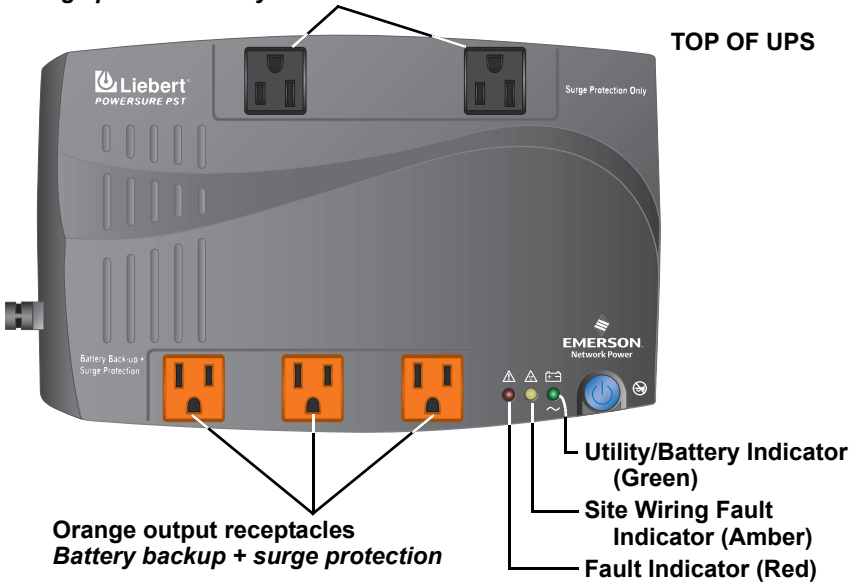

RIGHT SIDE OF UPS



LEFT SIDE OF UPS

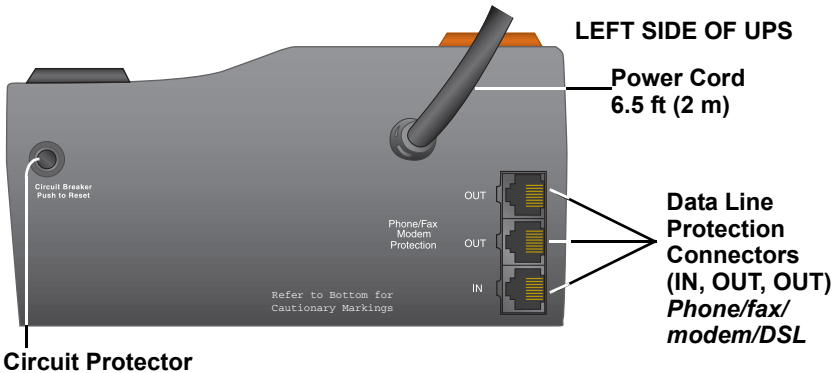

MAJOR COMPONENTS

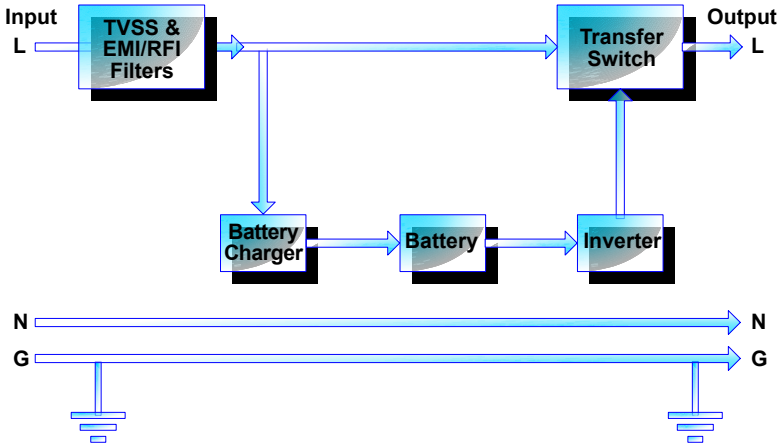

Transient Voltage Surge Suppression (TVSS) & EMI / RFI Filters

These UPS components provide surge protection and filter electromagnetic interference (EMI) and radio frequency interference (RFI). They minimize surges or interference present in the utility line and keep the sensitive equipment protected.

Transfer Switch

In Normal mode the Transfer Switch passes utility AC power to the connected load. When input utility voltage or frequency is outside acceptable limits, the transfer switch activates and transfers the UPS to battery.

Battery Charger

In Normal mode, the Battery Charger converts utility AC power into regulated DC power to float charge the battery. It is continuously charging the battery whenever the UPS is plugged into a power outlet and utility power is within acceptable limits—even if the UPS is turned OFF.

Battery

The PowerSure PST utilizes a valve-regulated, nonspillable, lead acid battery. To optimize battery life, operate the UPS in an ambient temperature of 68°-77°F (20°-25°C).

Inverter

When utility power fails, the Inverter draws energy from the battery and inverts it into a regulated stepped sinewave supplying power for equipment connected to the orange receptacles.

WHAT'S INCLUDED

The PowerSure PST is shipped with the following items:

- PowerSure PST user manual
- USB cable, 6 ft. (1.8m)
- RJ-11 cord, 7 ft. (2.1m)
- Warranty card

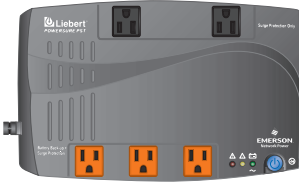

PowerSure PST



**USB cable
6-ft. (1.8m)**



**RJ-11 cord
7-ft. (2.1m)**

INSTALLATION

This UPS is designed for data processing equipment. Maximum load must not exceed that shown on the UPS rating label. Do not connect equipment that could overload the UPS or draw half-wave current from the UPS, for example: electric drills, vacuum cleaners, laser printers or hair dryers. Your total load earth leakage current must not exceed 3.5 mA. Most data processing equipment meets this requirement if you use no more than two pieces of equipment. If uncertain about your load, consult your local dealer, Liebert representative, or Liebert Worldwide Support Group.

1. Visually inspect the UPS for freight damage. Report damage to the carrier and your local dealer, Liebert representative or the Liebert Worldwide Support Group.
2. Decide where to place the PowerSure PST. Install the UPS indoors in a controlled environment, where it cannot be accidentally turned off. Place it in an area of unrestricted airflow around the unit, away from water, flammable liquids, gases, corrosives, and conductive contaminants. Maintain an ambient temperature range of 32°F to 104°F (0°C to 40°C).



NOTE

UPS operation in temperatures above 77°F (25°C) reduces battery life.

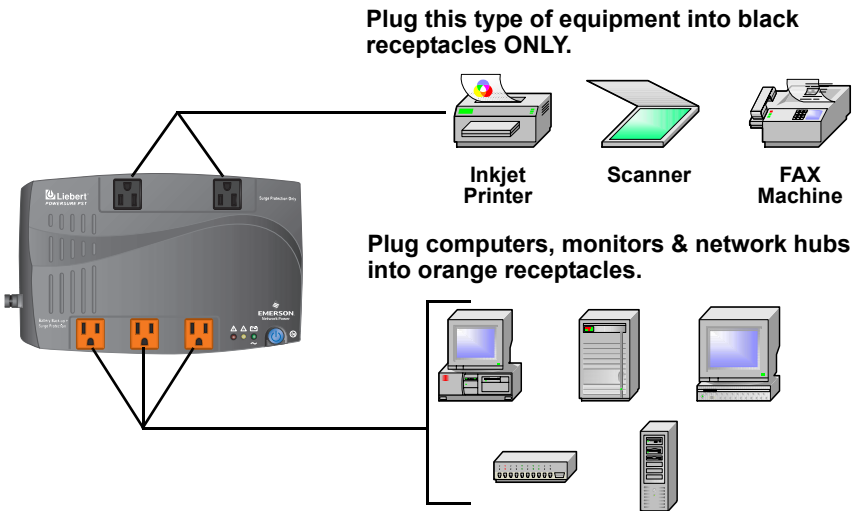

3. Plug the PowerSure PST's attached 6.5-ft. (2m) power cord into an AC outlet. Check that the Site Wiring Fault Indicator is not illuminated. If it is lit, refer to the **Troubleshooting** section.
4. Plug any computers and monitors into the orange battery backed up receptacles.

Other office machines that do not exceed the capacity of the UPS—inkjet printers, scanners and fax machines—may be plugged into either of the two (2) black receptacles, which provide surge protection only.

5. Connect Phone/Fax/DSL/Internet/Modem devices to data line connectors.

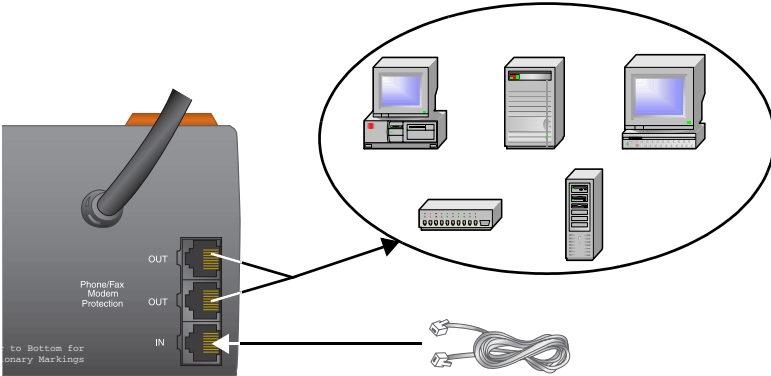

6. Press and release the ON/OFF/Alarm Silence button to turn on the UPS. The UPS will beep and the Utility/Battery Indicator will illuminate (green).
7. Turn on connected equipment.
8. Connect the USB cable provided with the UPS to the USB ports on the PST and your computer. The PST will work automatically with your built-in power management software on Windows XP and 2000 and Mac OS 10.2 or later (see **USB Interface Port** section for details).



NOTE

When using the communication features on this UPS, ensure the cabling connected to the UPS communications ports are kept separated from the power leads to the UPS input and output.

CONTROLS AND INDICATORS

ON/OFF/Alarm Silence Button



This button controls output power to the connected load and has three functions:

- ON
- OFF
- Alarm Silence

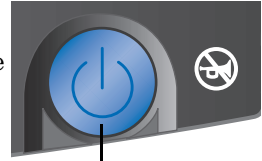

ON/OFF/Alarm Silence

ON When the UPS is off, pressing the main ON/OFF button for more than two seconds will start the UPS, and an audible alarm sounds briefly. The UPS is capable of starting on battery (*battery start*).

OFF When the UPS is on (in either Normal or Battery mode), pressing the main ON/OFF button for **more than two (2) seconds** will shut down the UPS. An audible alarm sounds briefly.

Alarm Silence When a UPS audible alarm is active, pressing and releasing the main ON/OFF button will silence the active audible alarm, whether utility power is present or not. Once the alarm silence function has been activated, all active audible alarms—except for low battery or overload conditions—will remain silenced until a new alarm condition is detected.



NOTE

Do not hold ON/OFF button down for more than 2 seconds or the UPS will shut down.

Status Indicators: Utility/Battery, Fault

There are two (2) status indicators on the top panel of the UPS, as shown in the diagram below. Each indicator illuminates to specify the status of the UPS (see **Troubleshooting** section for details).

Utility/Battery Indicator (Green)

The Utility/Battery Indicator illuminates when the UPS is operating in Normal mode, supplying power to connected loads. The Utility/Battery Indicator flashes when the UPS is operating in Battery mode.

Site Wiring Fault Indicator (Amber)

The Site Wiring Fault Indicator flashes amber when the UPS detects a line-neutral reversal or a poor neutral-ground bonding.

Fault Indicator (Red)

The Fault Indicator illuminates when the UPS detects an internal fault. It flashes if the UPS detects an overload condition.

Location and Status of Indicators

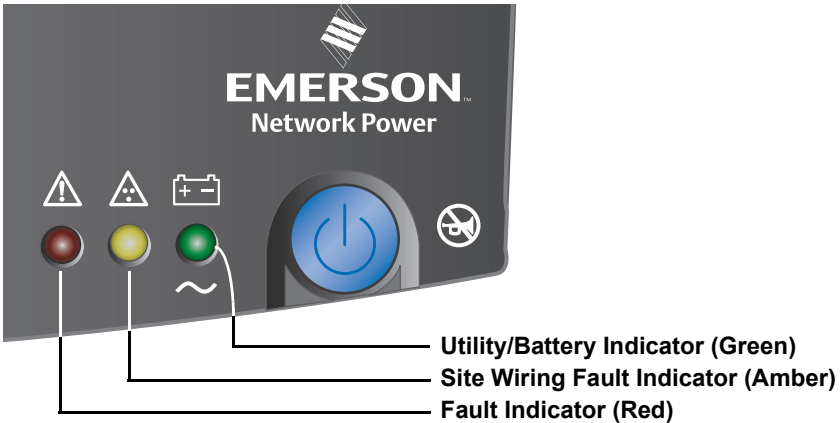

MODES OF OPERATION

Normal Mode

During Normal mode operation, the Power-Sure PST supplies conditioned, computer-grade power to the connected equipment: utility power passes through the TVSS circuitry, EMI/RFI filters and then through the Transfer Switch to the connected equipment.

When the UPS is in Normal mode, the Utility/Battery Indicator illuminates green.

The PowerSure PST continuously monitors the batteries to maintain them in a fully charged state. The battery charger operates whenever AC power is present, even if the UPS is switched off. The UPS performs an automatic battery test after it has been operating continuously for two (2) weeks.



Continuous LED illumination denotes Normal Mode

Battery Mode

The UPS switches to Battery mode in the event of an extreme voltage/frequency condition or complete utility failure. The battery system supplies power through the Inverter to generate power for connected equipment. When the UPS is in Battery mode, the Utility/Battery Indicator **flashes** green and an alarm sounds every 5 seconds.

When a low battery condition occurs, the Battery Indicator continues to flash green and the alarm sounds every half-second. Low battery warning is initiated when approximately two (2) minutes of battery run time are remaining. For more information, refer to **Troubleshooting** section.



Flashing LED illumination denotes Battery Mode



CAUTION

Turning off the UPS while in either Normal mode or Battery mode will result in the loss of output power.



NOTE

Once utility power is restored, the UPS resumes normal operation. At this time, the battery charger begins recharging the battery. The UPS is capable of OFF-State charging, i.e., with utility power, the UPS will charge the batteries as long as it is plugged in.

COMMUNICATIONS

USB Interface Port

The PowerSure PST has a USB interface port for communication that will work with the built-in Microsoft Power Manager software on the user's PC, if the PC is so equipped. It will provide UPS status and manages the automatic, orderly shutdown of the computer. The UPS (USB) communications meets HID standard, version 1.11. All USB models are compatible with Microsoft Windows 2000, Windows XP and Mac OS 10.2 or later. All USB models ship with a 6 ft. (1.8m) USB cable.



Microsoft, Windows, and the Windows logo are trademarks, or registered trademarks of Microsoft Corporation in the United States and/or other countries.

Data Line Protection Connectors

Data line (1 input & 2 outputs) connectors are located on the rear of the UPS and provide transient voltage surge suppression (TVSS) for Phone/Fax/DSL/Internet/Modem devices.

MAINTENANCE

The PowerSure PST UPS requires very little maintenance. Follow these practices to prevent problems.

Cleaning the UPS

The following will help ensure trouble-free operation for years:

- Vacuum dust from the ventilation intake occasionally.
- Wipe the cover periodically with a dry cloth.

Maintaining Batteries

The batteries are valve-regulated, nonspillable, lead acid and must be kept charged to retain their design life. The UPS continuously charges the batteries when connected to the utility supply, even while the UPS is switched off.

When storing the UPS, it is recommended to plug in UPS for at least 24 hours every four to six months to ensure full recharge of the batteries.

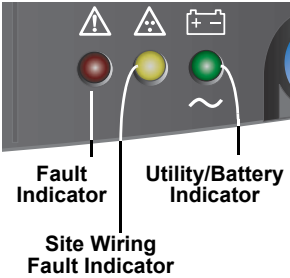

TROUBLESHOOTING

The information below indicates various symptoms a user may encounter in the event the PowerSure PST experiences a problem. Use this information to determine whether external factors caused the problem. See **Troubleshooting Chart** for suggested remedy.



1. The Fault Indicator illuminates, indicating the UPS detected a problem.
2. An alarm sounds, alerting that the UPS requires attention. The alarm can be silenced except for low battery and overload warning conditions.
3. Utility/Battery Indicator may be illuminated as a diagnostic aid to the operator, as shown below:

Guide to Status Indicators

Fault (Red) 	Site Wiring Fault (Amber) 	Utility/Battery (Green) 	Diagnosis/ Audible Alarm
Normal Mode			
—	—	● ON	UPS is operating in Normal Mode; no beep.
—	—	★ Flashing	Battery Test has been initiated; no beep.
—	★ Flashing	● ON	Site Wiring Fault; no beep.
★ Flashing	—	● ON	The unit is overloaded; beep every half-second
● ON	—	● ON	The UPS has failed; continuous beep
★ Flashing	—	—	Unit has shut down due to overload; continuous beep
● ON	—	—	The UPS shut down due to failure; continuous beep
Battery Mode			
—	—	★ Flashing	The UPS is operating in Battery mode; beep every 5 seconds.
—	—	★ Flashing	UPS battery is low; beep every half-second
★ Flashing	—	★ Flashing	The unit is overloaded; beep every half-second
● ON	—	★ Flashing	The UPS has failed; continuous beep

Troubleshooting Chart

If the UPS fails to operate properly, turn off the unit and repeat the steps in the **Installation** section of this manual. If the problem persists, refer to the chart below:

Problem	Cause	Solution
UPS will not start	Overload/ Short circuit	Check the circuit protector on the side of the UPS. If it is tripped, reset it and restart the UPS. For further help, call your local dealer, Liebert representative or the Liebert Worldwide Support Group.
UPS starts on battery, but will not switch to AC	UPS not plugged in	Plug in power cord securely.
	Circuit protector tripped	Reset the circuit protector and restart the UPS.
	Power not available at utility receptacle	Have the utility receptacle checked by a qualified electrician.
	Input voltage below threshold	Wait until the voltage rises to an appropriate level or have the utility receptacle checked by a qualified electrician.
	AC overvoltage	Wait until voltage lowers to an appropriate level or have the utility receptacle checked by a qualified electrician.
UPS shuts down, Fault Indicator lit	Overload/ Short circuit	Check the circuit protector on the rear of the UPS. If it is tripped, reset it and restart the UPS. If the problem persists, disconnect some of the equipment from your UPS—the total wattage of your equipment must not exceed the capacity of the UPS. For further help, call your local dealer, Liebert representative or the Liebert Worldwide Support Group.
	Internal UPS fault	
Site Wiring Fault Indicator illuminated	Line-neutral reversal/Poor ground connection	Have the utility checked by a qualified electrician.
UPS not providing expected backup time	Overload	Reduce load.
	Battery not charged due to a recent outage	Recharge battery.

SPECIFICATIONS

Model Number	PA350-120U	PA500-120U
Model Rating VA / W	350/225	500 / 300
DIMENSIONS: in (mm)		
Unit W x D x H	6.6 x 9.8 x 3.7 (168 x 250 x 95)	6.6 x 9.8 x 3.7 (168 x 250 x 95)
Shipping W x D x H	9.4 x 13.8 x 5.6 (238 x 350 x 142)	9.4 x 13.8 x 5.6 (238 x 350 x 142)
WEIGHT: lbs (kg)		
Unit	11.7 (5.3)	13.5 (6.1)
Shipping	12.1 (5.5)	13.9 (6.3)
INPUT AC PARAMETERS		
Surge Protection	603J	
Voltage Range Without Battery Operation	98VAC - 140VAC \pm 3VAC	
Frequency	57 - 63 Hz (\pm 0.4Hz)	
Input Power Cord	6.5 ft.attached, w/ NEMA 5-15 P	
OUTPUT AC PARAMETERS		
Output Receptacles	(3) NEMA 5-15R (orange) battery backup+surge protection (2) NEMA 5-15R (black) surge protection	
Voltage (Battery Mode)	120VAC \pm 8%	
Output Current	2.9 A	4.2 A
Waveform (Battery Mode)	Stepped Sinewave	
Frequency (Battery Mode)	60Hz \pm 1Hz	
Overload Warning	>100%	
Overload Shutdown	>110%	
BATTERY PARAMETERS		
Type	Valve-regulated, nonspillable, lead acid	
Quantity x Voltage x Rating	1 x 12V x 5 Ah	1 x 12V x 7 Ah
Transfer Time	4 – 6 ms typical	
Back-up Time:	At 77°F (25°C), resistive loading, w/ fully charged batteries:	
Full load	5 minutes	3 minutes
Half load	16 minutes	15 minutes
Recharge Time	12 hours to 90% capacity, after full discharge into resistive load	
ENVIRONMENTAL		
Operating Temperature	+32°F to + 104°F (0°C to +40°C)	
Storage Temperature	+5°F to + 122°F (-15°C to +50°C)	
Relative Humidity	0% to 95%, non-condensing	
Operating Elevation	Up to 10,000 ft. (3000 m) at 86°F (30°C) w/o derating	
Audible Noise	< 40 dBA, at 1 meter	
AGENCY		
Safety	UL 1778, c-UL Listed	
Surge	ANSI C62.41, Category A, Level 3, (IEEE 587, Category A); EN61000-4-5, Level 3, Criteria A	
ESD	EN61000-4-2, Level 3, Criteria A	
Susceptibility	EN61000-4-3, Level 2, Criteria A	
Electrical Fast Transient/Burst	EN61000-4-4, Level 3, Criteria A	
Emissions	FCC Part 15, Subpart B, Class B	
Harmonics	EN61000-3-2	
Conducted Immunity	EN61000-4-6	
Flicker	EN61000-3-3	
Transportation	ISTA Procedure 1A	

Battery Run Times

Load %	350VA	500VA
5	168	318
10	87	84
20	51	48
30	29	28
40	20	18
50	16	15
60	11	10
70	9	8
80	7	6
90	6	4
100	5	3

Note: Approximate discharge times are in minutes and at 77°F (25°C) with resistive load.

Product Warranty Registration

To register for warranty protection:

- Visit the **Quick Links** section of our Web site at:
<http://www.liebert.com>
- Click on **Product Warranty Registration** and fill in the form.

If you have any questions, please contact us at:

US: 800-222-5877

Outside the US: 614-841-6755

upstech@liebert.com



POWER AVAILABILITY

PowerSure™ PST

USER MANUAL

The Company Behind the Products

With over a million installations around the globe, Liebert is the world leader in computer protection systems. Since its founding in 1965, Liebert has developed a complete range of support and protection systems for sensitive electronics:

- Environmental systems—close-control air conditioning from 1 to 60 tons
- Power conditioning and UPS with power ranges from 300 VA to more than 1000 kVA
- Integrated systems that provide both environmental and power protection in a single, flexible package
- Monitoring and control—from systems of any size or location, on-site or remote
- Service and support through more than 100 service centers around the world and a 24/7 Customer Response Center

While every precaution has been taken to ensure the accuracy and completeness of this literature, Liebert Corporation assumes no responsibility and disclaims all liability for damages resulting from use of this information or for any errors or omissions.

© 2003 Liebert Corporation

All rights reserved throughout the world. Specifications subject to change without notice.

® Liebert and the Liebert logo are registered trademarks of Liebert Corporation. All names referred to are trademarks or registered trademarks of their respective owners.

SL-23275 (3/03) Rev. 1

Technical Support/Service

Web Site

www.liebert.com

Monitoring

800-222-5877

monitoring@liebert.com

Outside the US: 614-841-6755

Single-Phase UPS

800-222-5877

upstech@liebert.com

Outside the US: 614-841-6755

Three-Phase UPS

800-543-2378

powertech@liebert.com

Environmental Systems

800-543-2778

Outside the United States

614-888-0246

Locations

United States

1050 Dearborn Drive

P.O. Box 29186

Columbus, OH 43229

Italy

Via Leonardo Da Vinci 8

Zona Industriale Tognana

35028 Piove Di Sacco (PD)

+39 049 9719 111

Fax: +39 049 5841 257

Asia

23F, Allied Kajima Bldg.

138 Gloucester Road

Wanchai

Hong Kong

+852 2 572 2201

Fax: +852 2 831 0114

